

END VIEW- INLET & OUTLET HEADWALL

40.5 LF OF #46-L2 ALUMINUM BOX CULVERT WITH FULL ALUMINUM INVERT
 20'-3" SPAN X 8'-5" RISE
 MIN COVER= 1.4'
 MAX COVER= 4.0'
 HL-93 LOADING
 END AREA= 142.6 SF

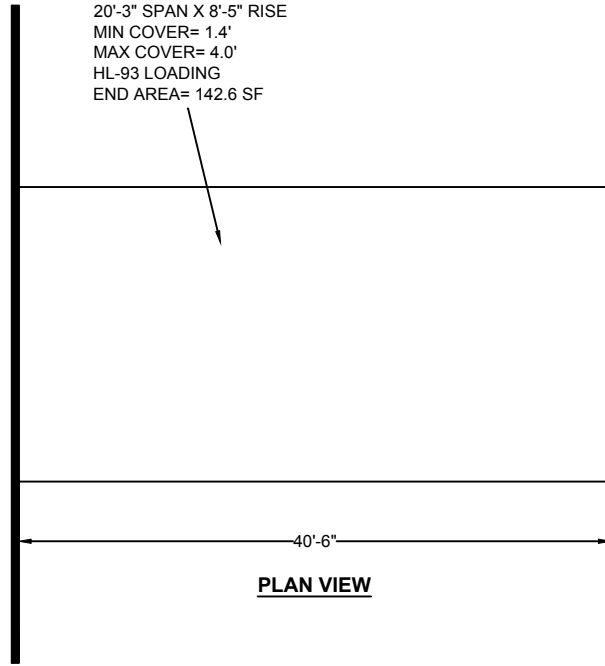

PLAN VIEW

PROPOSED ELEVATIONS:

TOP ϵ ROAD= 100.00
 TOP HW= 99.16
 TOP ALBC= 97.91
 INV STREAM= 90.00
 INV ALBC= 89.50

DESCRIPTION	
<p style="margin: 0;">NCDOT WILSON CO 5813 HOLDENS CROSSROADS SR-1514 WILSON NC</p>	
PROJECT:	
DATE: DEC 31, 2018	SHEET
NOT TO SCALE	

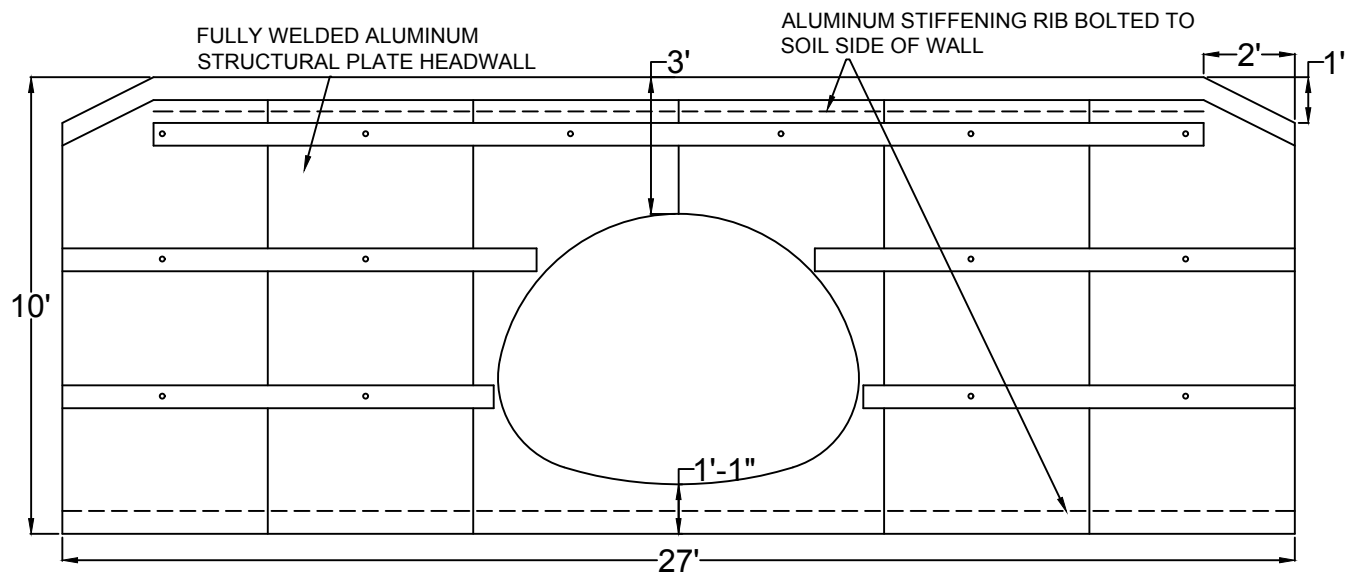

END VIEW- INLET HEADWALL

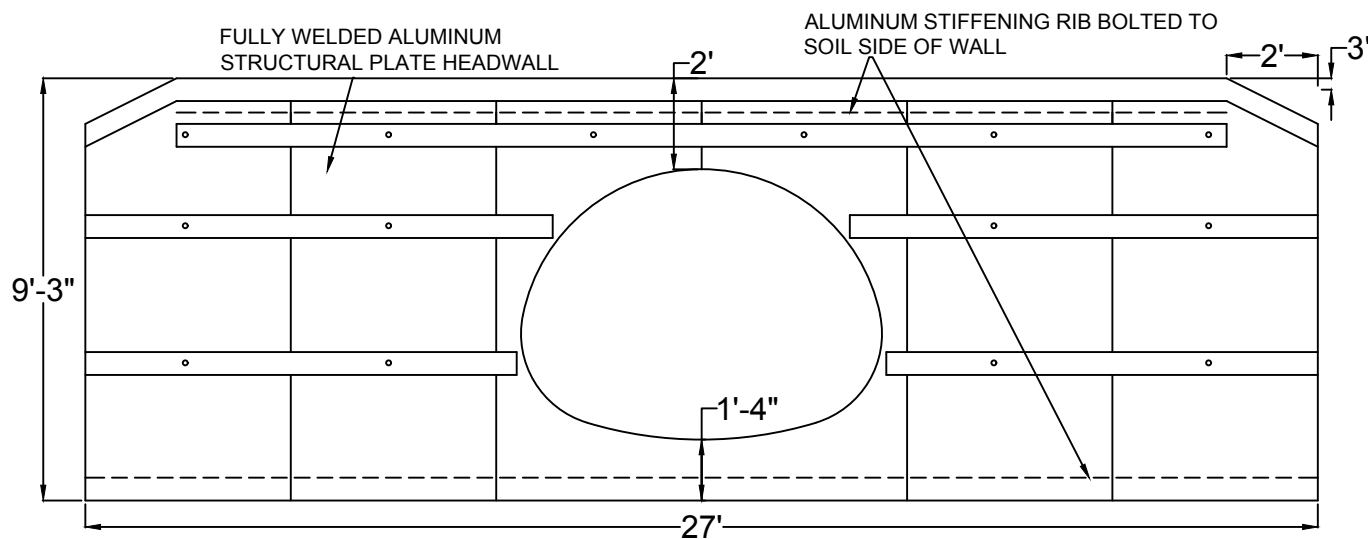

END VIEW- OUTLET HEADWALL

DESCRIPTION

NCDOT NASH CO
 2380 OLD WHITE OAK RD
 SR-1900
 NASHVILLE, NC

PROJECT:

DATE:
 DEC 31, 2018

SHEET

NOT TO SCALE

44 LF OF 103"x71", 8 GAGE, 3"x1" ALUMINUM PIPE WITH 2' WIDE
 BANDS & 2' WIDE FLAT GASKETS
 MIN COVER= 2.0'
 HL-93 LOADING

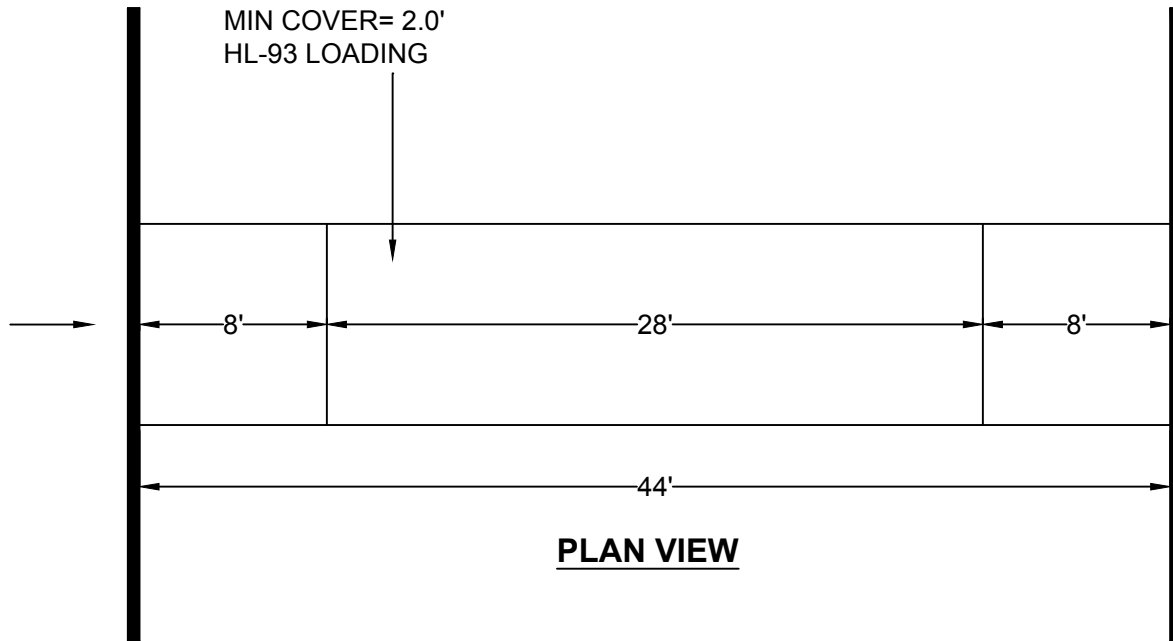

PLAN VIEW

PROPOSED ELEVATIONS:

EP INLET= 100.00
 EP OUTLET= 99.00
 TOP HW IN= 98.41
 TOP HW OUT= 97.41
 TOP PIPE= 95.41
 INV STREAM= 90.50
 INV PIPE= 89.50

DESCRIPTION	
NCDOT NASH CO 2380 OLD WHITE OAK RD SR-1900 NASHVILLE, NC	
FIRM:	
PROJECT:	
DATE: DEC 31, 2018	SHEET
NOT TO SCALE	

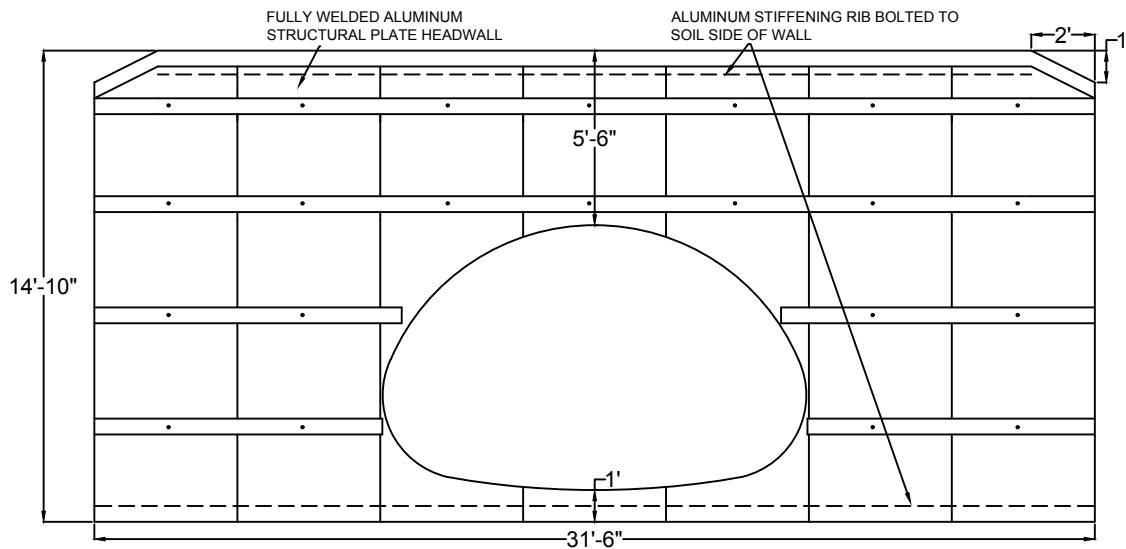

END VIEW- INLET & OUTLET HEADWALL

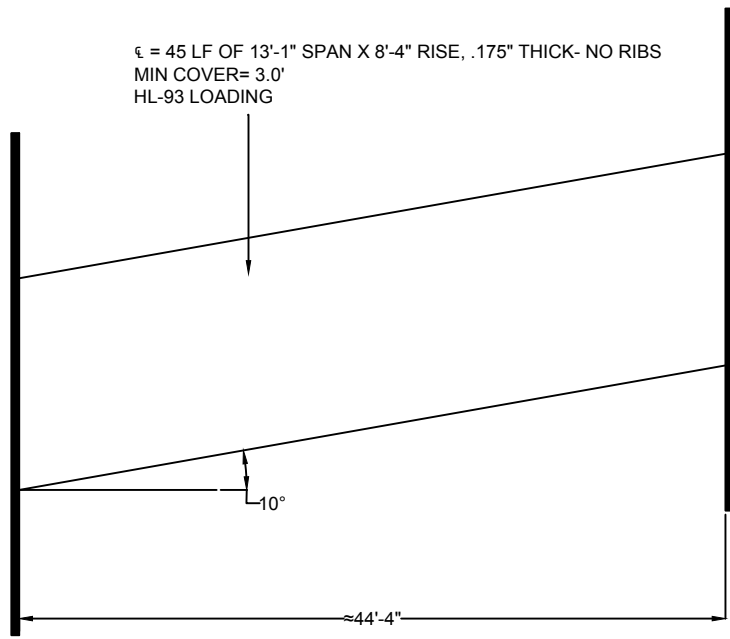

PLAN VIEW

PROPOSED ELEVATIONS:

- EP OUTLET= 100.00
- EP INLET= 99.00
- TOP HW= 95.83
- TOP PIPE= 90.33
- INV STREAM= 83.00
- INV PIPE= 82.00

DESCRIPTION	
<p>NCDOT NASH CO 2974 PEACHTREE HILLS ROAD SR-1312 SPRING HOPE, NC</p>	
DATE: JAN 7, 2018	SHEET
NOT TO SCALE	

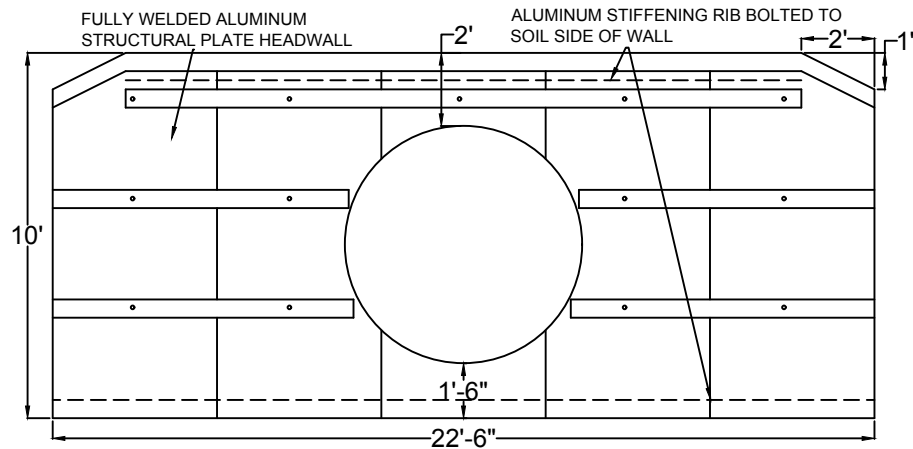

END VIEW- INLET HEADWALL

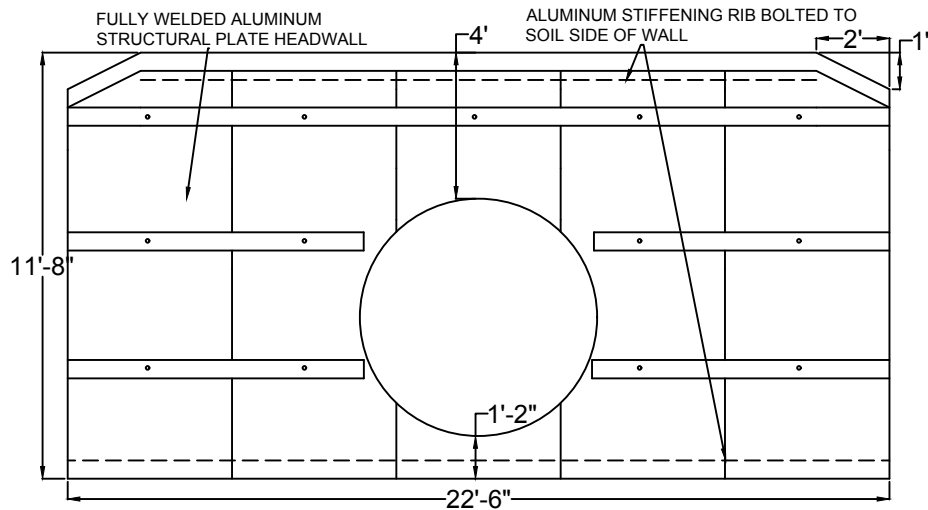

END VIEW- OUTLET HEADWALL

DESCRIPTION

NCDOT NASH CO- SR-1953
 6556 SQUIRREL DEN RD
 BAILEY, NC
 * THIS SITE IS WATER POINT FOR STAN HOPE FIRE DISTRICT 19-22

POMONA PIPE PRODUCTS
 4611 DUNDAS DR.
 GREENSBORO, NC 27407
 336-292-8060

PROJECT:

DATE: DEC 21, 2018	SHEET
NOT TO SCALE	

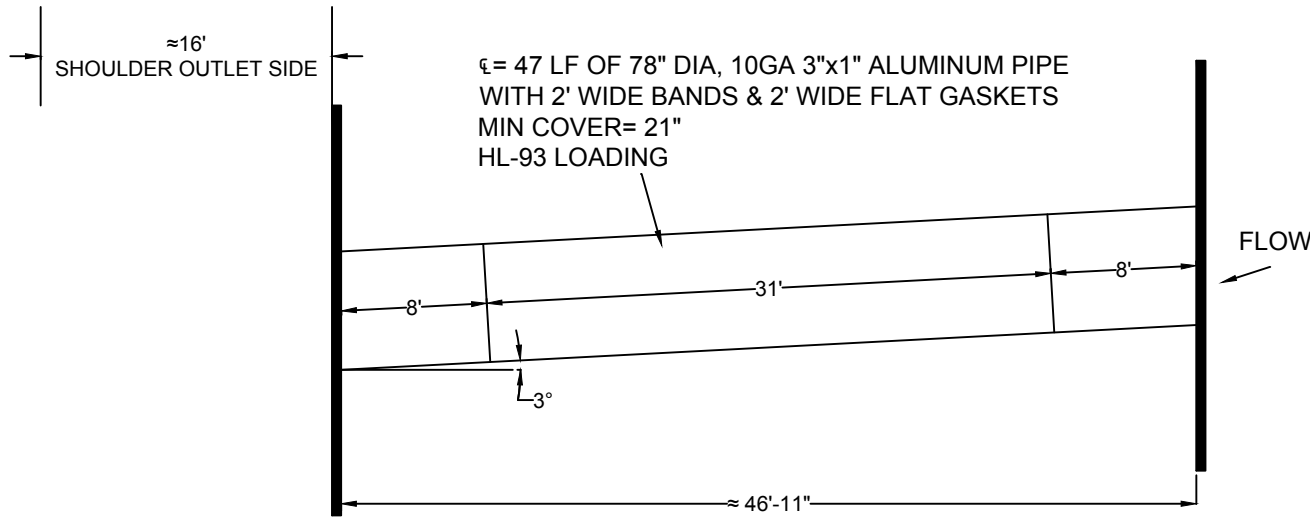

PLAN VIEW

PROPOSED ELEVATIONS:

EP OUTLET= 100.00
 EP INLET= 99.34
 TOP HW OUT= 98.50
 TOP HW IN= 98.00
 TOP OF PIPE IN= 96.00
 TOP PIPE OUT= 94.50
 INV STREAM IN= 90.34
 INV PIPE IN= 89.50
 INV STREAM OUT= 89.00
 INV PIPE OUT= 88.00

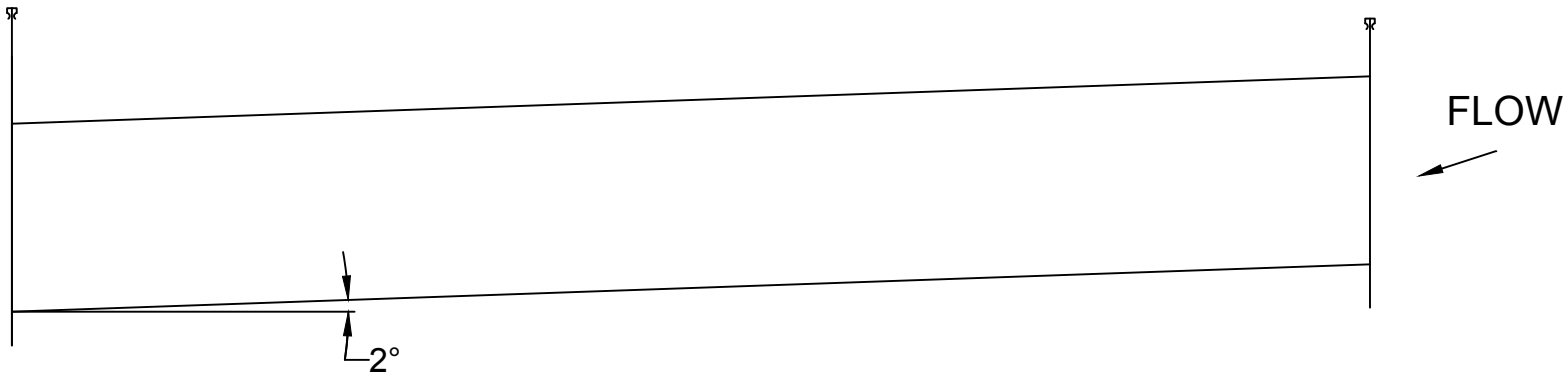

SIDE VIEW

DESCRIPTION

NCDOT NASH CO- SR-1953
 6556 SQUIRREL DEN RD
 BAILEY, NC
 *THIS SITE IS WATER POINT FOR STAN HOPE FIRE DISTRICT 19-22

POMONA PIPE PRODUCTS
 4611 DUNDAS DR
 GREENSBORO, NC 27407
 336-292-8060

PROJECT:

DATE:
 DEC 21, 2018

SHEET

NOT TO SCALE

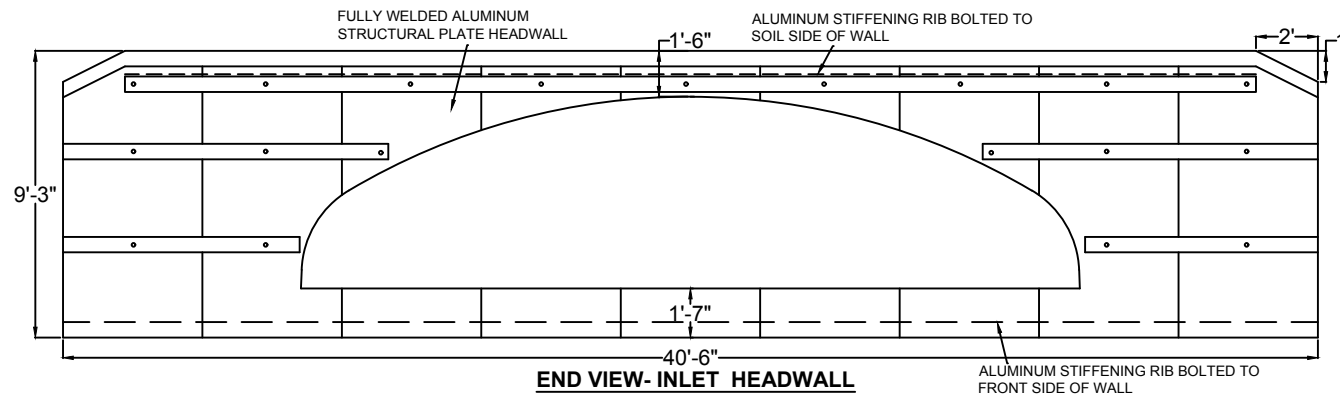

END VIEW- INLET HEADWALL

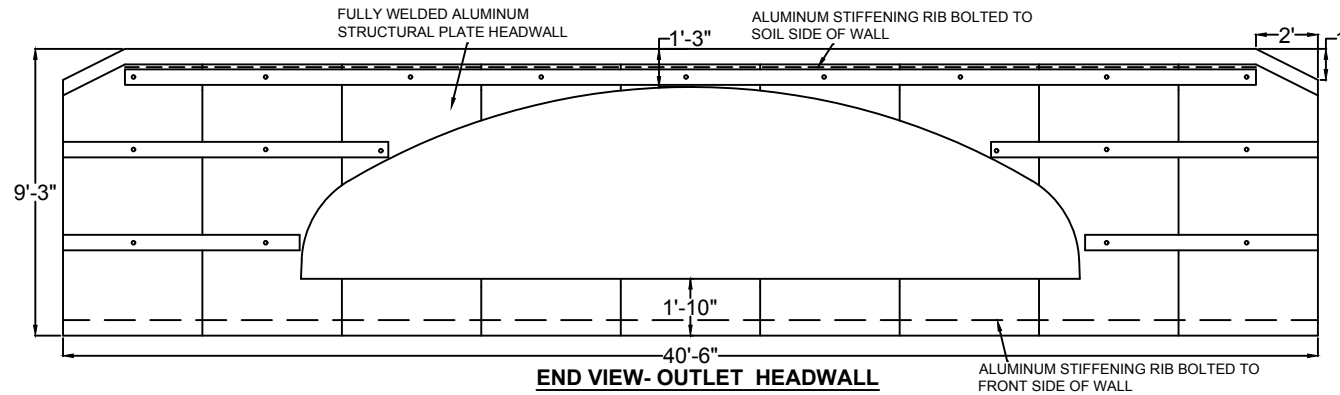

END VIEW- OUTLET HEADWALL

DESCRIPTION

NCDOT WAYNE CO
 SR 1339
 219 PINKNEY CHURCH RD
 FREMONT, NC

PROJECT:

DATE:
 DEC 28, 2018

SHEET

NOT TO SCALE

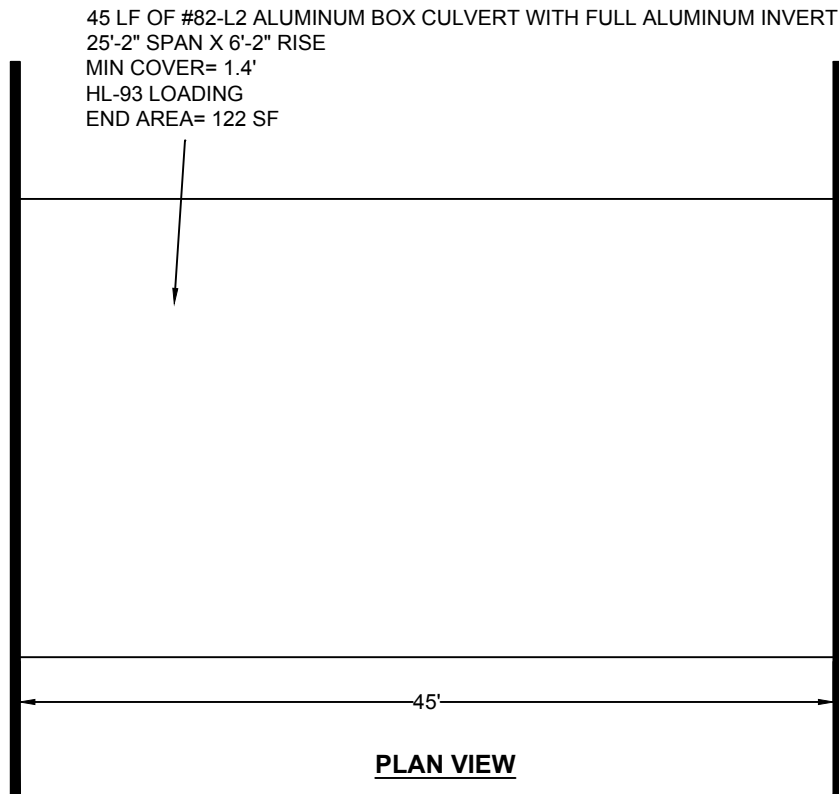

PROPOSED ELEVATIONS:

EP INLET= 100.00
 EP OUTLET= 99.00
 TOP HW IN= 98.91
 TOP HW OUT= 98.66
 TOP ALBC= 97.41
 INV STREAM= 92.50
 INV ALBC= 91.5

* INCLUDES 1 ROLL TX GEOGRID

DESCRIPTION	
NCDOT WAYNE CO SR 1339 219 PINKNEY CHURCH RD FREMONT, NC	
FIRM:	
PROJECT:	
DATE: DEC 28, 2018	SHEET
NOT TO SCALE	